

Lighting Application

■ Features

1. RoHS compliant
2. For frequent switching
3. Small size
4. Low, medium, and high resistance ratings
5. Stable over a long life
6. Operating temperature range: 0 ~ +60°C (V=Vmax)
-25 ~ +125°C (V=0)

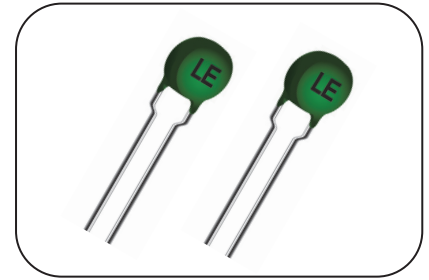

■ Recommended Applications

1. Electronic ballast for lamps, switching
2. Energy saving lamp

■ Part Number Code

P	L	A	0	3	1	5	1	N	P	8	D	2	Y		
1	2	3	4	5	6	7	8	9	10	11	12	13	14	15	16

Product Code		Dimensions		Resistance (R₂₅)		Tolerance of R₂₅		Curie Temperature		Withstanding Voltage (V_w)		Packaging		Internal Control Code	
PL	Ceramic PTC Thermistor PL Series	03	φ 3mm	850	85Ω	M	±20%	P6	60°C	C2	320V	Y	Bulk		
		06	φ 6mm	151	150Ω	H	±25%	P8	80°C	D2	420V	X	Ammo Box Pitch 12.7mm		
				152	1.5KΩ	N	±30%	A0	100°C	E0	500V	V	Ammo Box Pitch 15mm		
						T	±40%	A2	120°C	F0	600V	W	Taping & Reel Pitch 12.7mm		
						S	+35 ~ -15%			G0	700V	U	Taping & Reel Pitch 15mm		
						Q	+30 ~ -20%			H0	800V				
						Y	Special								

Series	
A	Leaded Type

■ Dimensions

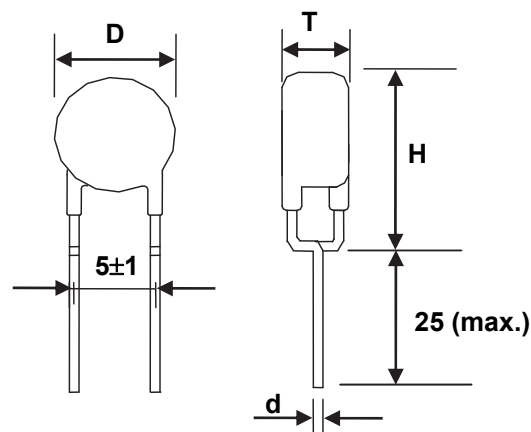

(Unit: mm)

Ceramic PTC Thermistor: PLA Series

Lighting Application



■ Characteristics

Part No.	Curie Temperature	Zero-power Resistance at 25°C	Withstanding Voltage	Maximum Current	Dimensions			
	T _c (°C)	R ₂₅ (Ω)	V _w (V _{ac})	I _{max} (mA)	D(mm)	T(mm)	d±0.02(mm)	H _{max} (mm)
PLA03101□**D2	(50/60/70/ 80/90/100/ 110/120) ±10	100	420	200	3.0~4.5	3.5~4.5	0.5	8.5
PLA03151□**D2		150	420					
PLA03221□**D2		220	420					
PLA03331□**E0		330	500					
PLA03471□**E0		470	500					
PLA03681□**E0		680	500					
PLA03102□**F0		1000	600					
PLA03152□**F0		1500	600					
PLA03222□**F0		2200	600					
PLA03332□**F0		3300	600					
PLA03472□**F0		4700	600					
PLA04680□**D2		68	420					
PLA04101□**D2		100	420					
PLA04151□**D2		150	420					
PLA04221□**E0		220	500					
PLA04331□**E0		330	500					
PLA04471□**F0		470	600					
PLA04681□**F0		680	600					
PLA04102□**F0		1000	600					
PLA04152□**F0		1500	600					
PLA04222□**F0		2200	600					
PLA04332□**F0		3300	600					
PLA05680□**D2		68	420	400	5.0~6.5	3.5~4.5	0.6	10.5
PLA05101□**D2		100	420					
PLA05151□**D2	150	420						
PLA05221□**E0	220	500						
PLA05331□**E0	330	500						
PLA05471□**F0	470	600						
PLA05681□**F0	680	600						
PLA05102□**F0	1000	600						
PLA05152□**F0	1500	600						
PLA05222□**F0	2200	600						
PLA05332□**F0	3300	600						
PLA06680□**D5	68	450	600					
PLA06101□**E0	100	500						
PLA06151□**E0	150	500						
PLA06221□**F0	220	600						
PLA06331□**F0	330	600						
PLA06471□**F0	470	600						

Note:

- is the tolerance of R₂₅
- ** is the code of T_c (Curie temperature)
- V_w: Withstanding voltage at 50Hz.

Lighting Application

Part No.	Curie Temperature	Zero-power Resistance at 25°C	Withstanding Voltage	Maximum Current	Dimensions			
	T _c (°C)	R ₂₅ (Ω)	V _w (V _{ac})	I _{max} (mA)	D(mm)	T(mm)	d±0.02(mm)	H _{max} (mm)
PLA06681□**F5	(50/60/70/ 80/90/100/ 110/120) ±10	680	650	600	5.5~7.5	3.5~4.5	0.6	11.5
PLA06102□**F5		1000	650					
PLA06152□**F5		1500	650					
PLA06222□**F5		2200	650					
PLA07680□**D5		68	450	800	6.5~8.5	3.5~4.5	0.6	12.5
PLA07101□**E0		100	500					
PLA07151□**E0		150	500					
PLA07221□**F0		220	600					
PLA07331□**F0		330	600					
PLA07471□**F0		470	600					
PLA07681□**F5		680	650					
PLA07102□**F5		1000	650					
PLA07152□**F5		1500	650					
PLA07222□**F5		2200	650					

Note:

- is the tolerance of R₂₅
- ** is the code of T_c (Curie temperature)
- V_w: Withstanding voltage at 50Hz.

Lighting Application

■ Soldering Recommendation

● Wave Flow Soldering Profile

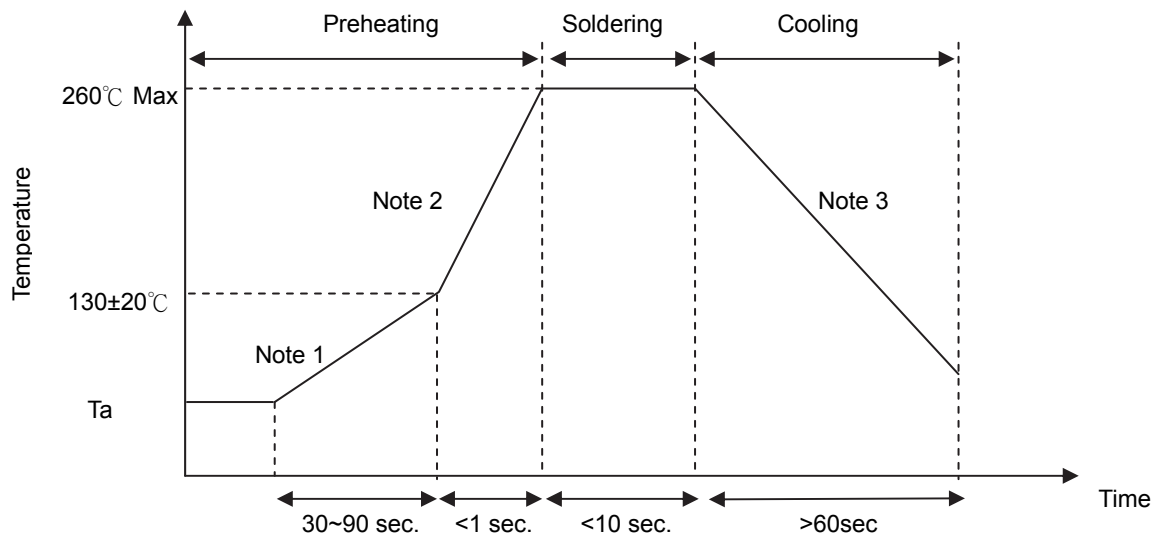

Note

1. $(1 \sim 3^\circ\text{C})/\text{sec.}$
2. Approx. $200^\circ\text{C}/\text{sec.}$
3. $5^\circ\text{C}/\text{sec. (Max)}$

■ Recommended Reworking Conditions With Soldering Iron

Item	Conditions
Temperature of Soldering Iron-tip	360°C (max.)
Soldering Time	3 sec (max.)
Distance from Coating	2 mm (min.)

Lighting Application

■ Reliability Test

Item	Standard	Test Conditions and Methods	Specifications															
Robustness of Terminations	IEC 60738-1	<p>Gradually apply the specified force and keep the unit fixed for 10±1 sec.</p> <table border="1"> <thead> <tr> <th>Terminal diameter (mm)</th> <th>Force T(N)</th> </tr> </thead> <tbody> <tr> <td>0.35<d≤0.5</td> <td>5.0</td> </tr> <tr> <td>0.5<d≤0.8</td> <td>10.0</td> </tr> <tr> <td>0.8<d≤1.25</td> <td>20.0</td> </tr> </tbody> </table>	Terminal diameter (mm)	Force T(N)	0.35<d≤0.5	5.0	0.5<d≤0.8	10.0	0.8<d≤1.25	20.0	$ \Delta R_{25}/R_{25} \leq 20\%$ No visible damage							
Terminal diameter (mm)	Force T(N)																	
0.35<d≤0.5	5.0																	
0.5<d≤0.8	10.0																	
0.8<d≤1.25	20.0																	
Solderability	IEC 60738-1	245±3 °C , 2±0.5 sec	At least 95% of terminal electrode is covered by new solder															
Resistance to Soldering Heat	IEC 60738-1	260±3 °C , 10±1 sec	$ \Delta R_{25}/R_{25} \leq 20\%$ No visible damage															
Vibration	IEC 60738-1	Frequency range:10~55Hz Amplitude: 0.75mm or 98m/s ² Direction: 3 mutually perpendicular directions Duration: 6hrs(3x2 hrs)	$ \Delta R_{25}/R_{25} \leq 20\%$ No visible damage															
Shock	IEC 60738-1	Wave: half-sine ΔV: 1.0m/s Acceleration: 50 m/s ² Pulse time: 30ms	$ \Delta R_{25}/R_{25} \leq 20\%$ No visible damage															
Rapid Change of Temperature	IEC 60738-1	The thermal shock conditions shown below shall be repeated 5 cycles. <table border="1"> <thead> <tr> <th>Step</th> <th>Temperature (°C)</th> <th>Period (minutes)</th> </tr> </thead> <tbody> <tr> <td>1</td> <td>-40 ± 5</td> <td>30 ± 3</td> </tr> <tr> <td>2</td> <td>Room temperature</td> <td>5 ± 3</td> </tr> <tr> <td>3</td> <td>85 ± 5</td> <td>30 ± 3</td> </tr> <tr> <td>4</td> <td>Room temperature</td> <td>5 ± 3</td> </tr> </tbody> </table>	Step	Temperature (°C)	Period (minutes)	1	-40 ± 5	30 ± 3	2	Room temperature	5 ± 3	3	85 ± 5	30 ± 3	4	Room temperature	5 ± 3	$ \Delta R_{25}/R_{25} \leq 20\%$ No visible damage
Step	Temperature (°C)	Period (minutes)																
1	-40 ± 5	30 ± 3																
2	Room temperature	5 ± 3																
3	85 ± 5	30 ± 3																
4	Room temperature	5 ± 3																
Climatic Sequence	IEC 60738-1	Dry heat: 125 °C for 16 hrs Damp heat first cycle: 40°C, 95% R.H, cycle time: 24 hrs Cold: -25°C for 2 hrs Damp heat (cyclic), remaining cycles: 5 cycles Test according to IEC60068-2-30	$ \Delta R_{25}/R_{25} \leq 20\%$ No visible damage															
Damp Heat, Steady State	IEC 60738-1	40±2°C, 90~95% RH, for 1000±2hrs	$ \Delta R_{25}/R_{25} \leq 20\%$ No visible damage															
Endurance at maximum operating temperature and maximum voltage	IEC60738-1	UCT=60°C, 270V _{ac} , I ≤ I _{max} for 1000±2hrs.	$ \Delta R_{25}/R_{25} \leq 20\%$ No visible damage															
Endurance at maximum voltage	IEC60738-1	25±5°C, 270V _{ac} , I ≤ I _{max} 1min. on and 5min. Off ×10,000 cycles	$ \Delta R_{25}/R_{25} \leq 20\%$ No visible damage															

Ceramic PTC Thermistor: PLA Series

Lighting Application

■ Packaging

■ Taping Specification

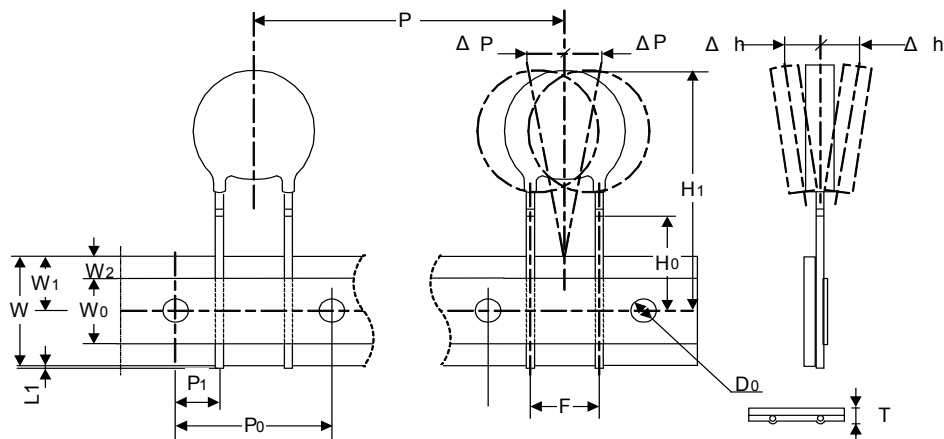

■ Parameter List

(Unit: mm)

Index	Parameter	Nominal dimensions	Tolerance														
F	Lead spacing	5	±1														
P ₀	Sprocket hole pitch	12.7	±0.3														
P ₁	Ordinate to adjacent component lead	3.85	±1														
P	Device pitch	12.7	±1														
H ₀	Abscissa to plane (kinked lead)	16	±0.5														
H ₁	Abscissa to top	<table border="1"> <thead> <tr> <th>D*</th> <th>3</th> <th>4</th> <th>5</th> <th>6</th> <th>7</th> <th>8</th> </tr> </thead> <tbody> <tr> <td>H₁</td> <td>24</td> <td>25</td> <td>26</td> <td>27</td> <td>28</td> <td>29</td> </tr> </tbody> </table>	D*	3	4	5	6	7	8	H ₁	24	25	26	27	28	29	Max.
D*	3	4	5	6	7	8											
H ₁	24	25	26	27	28	29											
W	Carrier tape width	18	±1														
W ₀	Hold-down tape width	12	±1														
W ₁	Sprocket hole position	9	±1														
W ₂	Top distance between tape edges	3	Max.														
ΔP	Body tape plane deviation	1	Max.														
Δh	Body lateral deviation	2	Max.														
L ₁	Lead protrusion	0.5	Max.														
D ₀	Sprocket hole diameter	4	±0.2														
T	Tape thickness	0.6	±0.2														

Note: D: Disc diameter

Lighting Application

■ Quantity

● Bulk Packing:

200pcs per bag

■ Reel Packing:

1,500pcs per reel

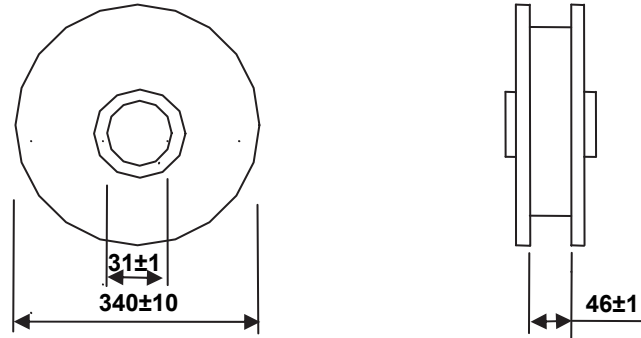

(Unit: mm)

■ Ammo packing:

1,000pcs per box

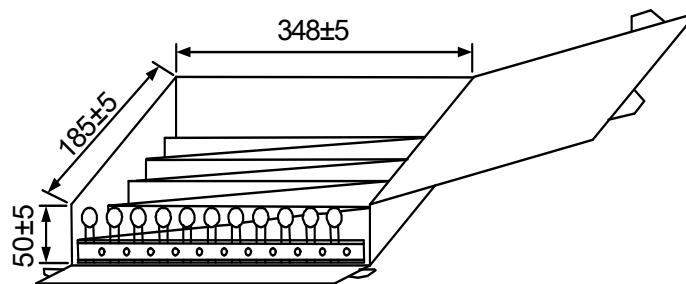

■ Warehouse Storage Conditions of Products

● Storage Conditions :

1. Storage Temperature : $-10^{\circ}\text{C} \sim +40^{\circ}\text{C}$
2. Relative Humidity : $\leq 75\% \text{RH}$
3. Keep away from corrosive atmosphere and sunlight.

● Period of Storage : 1 year

■ Usage

Please keep products away from the conditions mentioned below to avoid their characteristic deterioration and failure.

1. Corrosive gas or deoxidizing gas (Cl_2 , H_2S , NH_3 , SO_x , NO_x etc.)
2. Place in a vacuum or put pressure
3. Salt water, oil, solvent and chemical liquid
4. Flammable gas
5. Place in splashed water, or high humidity and dewing place
6. Other places similar to any conditions mentioned above