

Ceramic PTC Thermistor: PPL Series

Twin SMD Type for Telecom Application

■ Features

1. RoHS compliant
2. Two resistance-matched PTCs in a plastic housing
3. Wide resistance range in telecom area from 10 to 50Ω
4. Compliant with ITU-T standards
5. Operating temperature range :
0 ~ +60°C (V=Vmax)
-25 ~ +125°C (V=0)
6. Agency recognition: UL/cUL,TUV
UL/cUL File No. E138827
TUV File No. R 50171789

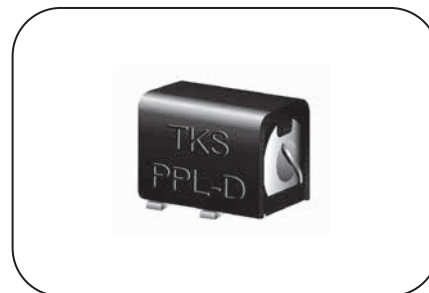

■ Recommended Applications

1. Cable Modem, ADSL Modem with VOIP
2. Customer Premise Equipment (CPE)
3. Central Office (CO)
4. Access Equipment (AE)
5. Main Distribution Frame (MDF)
6. Public Switched Telephone Network (PSTN)
7. Exchanger

■ Part Number Code

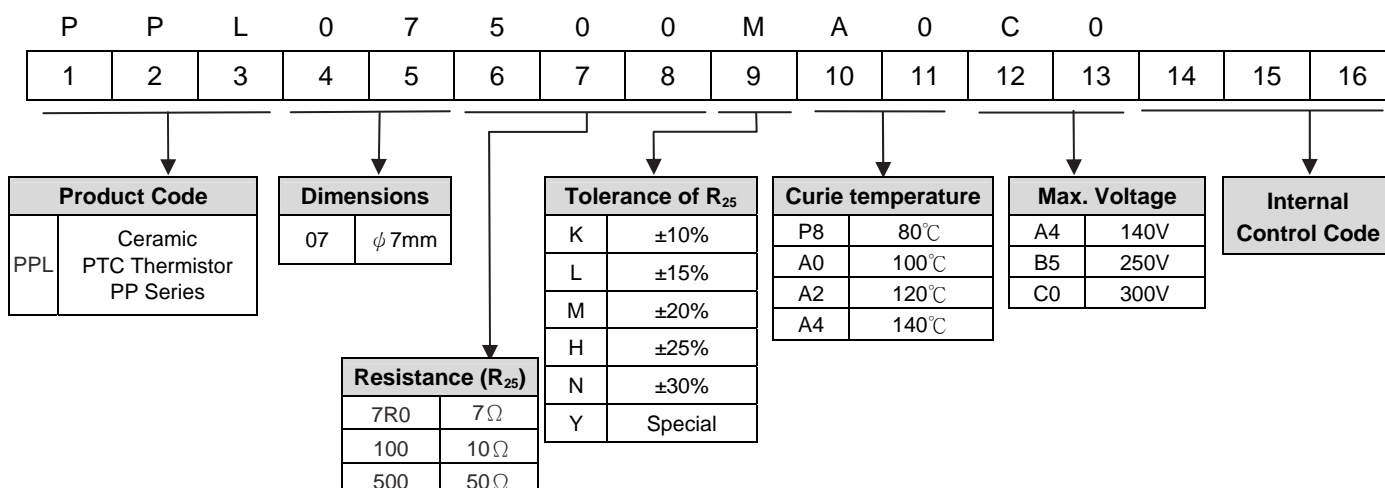

Ceramic PTC Thermistor: PPL Series

Twin SMD Type for Telecom Application

■ Structure and Dimensions

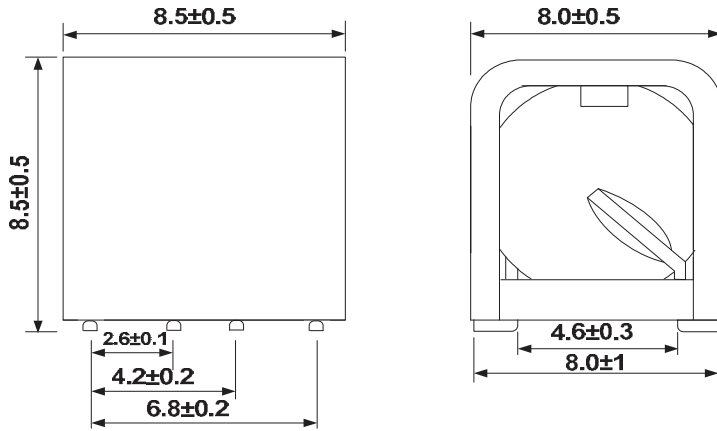

■ Solder pad

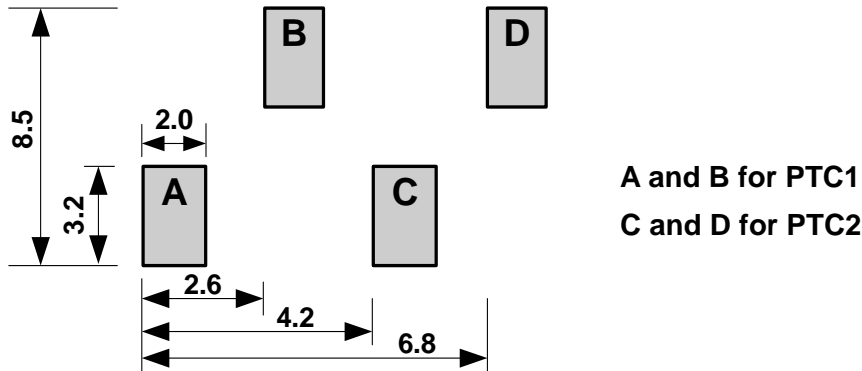

■ Characteristics

Part No.	Zero-power Resistance at 25°C	Resistance Matching In Housing	Non-operating Current at 25°C	Non-operating Current at 40°C	Trip Current at 25°C	Responding Time (s)			Max Voltage	With-standing Voltage	Max. Current	Safety Approvals	
	R ₂₅ (Ω)		R1-R2 (Ω)	I _N (mA) @25°C	I _N (mA) @40°C	I _T (mA) @25°C	3A→0.5A	1A→0.5A	0.5A→0.15A	V _{max} (V _{ac})	V _w (V _{ac})	I _{max} (A)	UL/cUL
PPL07100□A0B5-Y	10	±0.5	130	120	390	0.8	8.0	35	250	250	2.5	√	√
PPL07180□A0B5-Y	18		110	100	330	0.4	2.5	10	250	250	3	√	√
PPL07250□A0B5-Y	25		90	80	225	0.35	2.0	10	250	250	3	√	√
PPL07390□A0B5-Y	39		70	65	180	0.3	1.0	4.0	250	250	3	√	√
PPL07500□A0C0-Y	50		60	55	165	0.15	0.8	3.5	300	600	3	√	√

Note : □ is the tolerance of R₂₅

Ceramic PTC Thermistor: PPL Series

Twin SMD Type for Telecom Application

■ R-T Characteristic Curves (Typical)

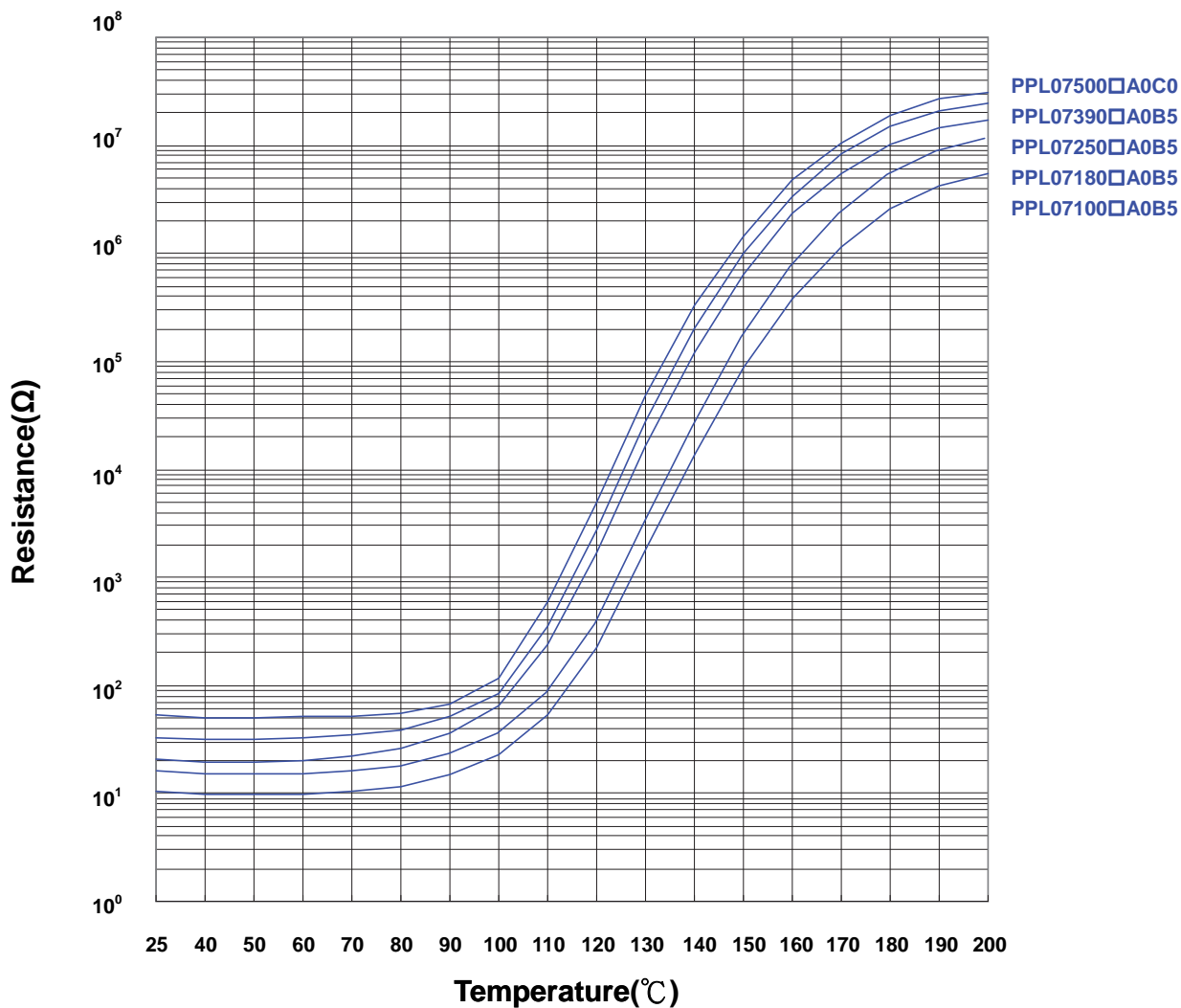

■ Circuit for Typical Application

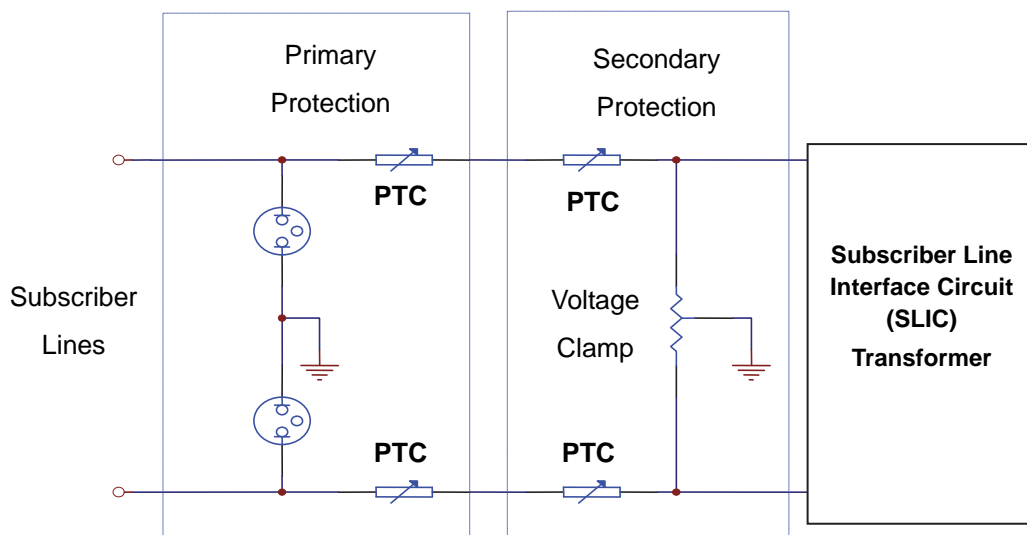

Ceramic PTC Thermistor: PPL Series

Twin SMD Type for Telecom Application

■ Soldering Recommendation

● IR-Reflow Soldering Profile

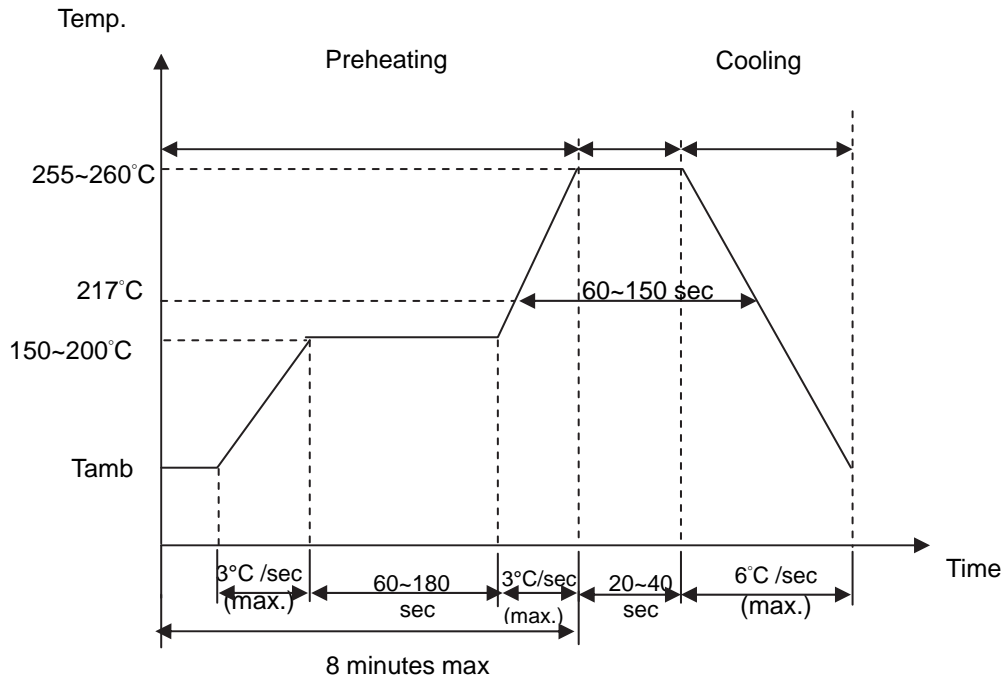

● Recommended Reworking Conditions With Soldering Iron

Item	Conditions
Temperature of Soldering Iron-tip	360°C (max.)
Soldering Time	3 sec (max.)
Diameter of Soldering Iron-tip	3mm (max.)

Ceramic PTC Thermistor: PPL Series

Twin SMD Type for Telecom Application

■ Reliability Test

Item	Standard	Test conditions and methods	Specifications															
Solderability	IEC 60738-1	245±3 °C , 2±0.5 sec	At least 95% of terminal electrode is covered by new solder															
Resistance to Soldering Heat	IEC 60738-1	260±3 °C , 10±1 sec	$\Delta R_{25}/R_{25}$ ≤ 20% No visible damage															
Vibration	IEC 60738-1	Frequency range:10~55Hz Amplitude: 0.75mm or 98m/s ² Direction: 3 mutually perpendicular directions Duration: 6hrs(3x2 hrs)	$\Delta R_{25}/R_{25}$ ≤ 20% No visible damage															
Shock	IEC 60738-1	Wave: half-sine ΔV : 1.0m/s Acceleration: 50 m/s ² Pulse time: 30ms	$\Delta R_{25}/R_{25}$ ≤ 20% No visible damage															
Rapid Change of Temperature	IEC 60738-1	The thermal shock conditions shown below shall be repeated 5 cycles. <table border="1" data-bbox="502 981 1193 1196"> <thead> <tr> <th>Step</th> <th>Temperature (°C)</th> <th>Period (minutes)</th> </tr> </thead> <tbody> <tr> <td>1</td> <td>-40 ± 5</td> <td>30 ± 3</td> </tr> <tr> <td>2</td> <td>Room temperature</td> <td>5 ± 3</td> </tr> <tr> <td>3</td> <td>85 ± 5</td> <td>30 ± 3</td> </tr> <tr> <td>4</td> <td>Room temperature</td> <td>5 ± 3</td> </tr> </tbody> </table>	Step	Temperature (°C)	Period (minutes)	1	-40 ± 5	30 ± 3	2	Room temperature	5 ± 3	3	85 ± 5	30 ± 3	4	Room temperature	5 ± 3	$\Delta R_{25}/R_{25}$ ≤ 20% No visible damage
Step	Temperature (°C)	Period (minutes)																
1	-40 ± 5	30 ± 3																
2	Room temperature	5 ± 3																
3	85 ± 5	30 ± 3																
4	Room temperature	5 ± 3																
Climatic Sequence	IEC 60738-1	Dry heat: 125 °C for 16 hrs Damp heat first cycle: 40°C , 95% R.H ,cycle time: 24 hrs Cold: -40°C for 2 hrs Damp heat (cyclic), remaining cycles: 5 cycles Test according to IEC60068-2-30	$\Delta R_{25}/R_{25}$ ≤ 20% No visible damage															
Damp Heat, Steady State	IEC 60738-1	40±2°C, 90~95% RH, for 1000±2hrs	$\Delta R_{25}/R_{25}$ ≤ 20% No visible damage															
Endurance at Maximum Operating Temperature and Maximum Voltage	IEC60738-1	60°C, Vmax, It<I<Imax for 1000±2hrs	$\Delta R_{25}/R_{25}$ ≤ 20% No visible damage															
Over Current	Specification Standard	220Vrms, 3A, 60s on and 600s off , x20 cycles	$\Delta R_{25}/R_{25}$ ≤ 20% No visible damage															
Power Contact	ITU-T K.20 9.4	230Vrms,10Ω, 15Min.	No fire hazard															
Lightning Surge	ITU-T K30 4.2.5	DC:1.0KV, 10/1000μs,25A,x30 cycles DC:1.5KV, 10/310μs,37.5A,x10cycles	$\Delta R_{25}/R_{25}$ ≤ 20% No visible damage															
Power Induction	Specification Standard	600Vrms,600Ω,1s on and 60s off ,10 cycles (For Vw=600V only)	$\Delta R_{25}/R_{25}$ ≤ 20% No visible damage															

Ceramic PTC Thermistor: PPL Series

Twin SMD Type for Telecom Application

■ Packaging

● Taping Specification

Item	Nominal dimensions	Tolerance
W	16.00	±0.30
P	16.00	±0.10
E	1.75	±0.10
F	7.50	±0.10
P2	2.00	±0.10
P0	4.00	±0.10
D0	1.50	+0.10/-0.00
D1	1.50	+0.10/-0.00
A0	8.4	±0.10
B0	8.9	±0.10
K0	9.3	±0.10
t	0.5	±0.05

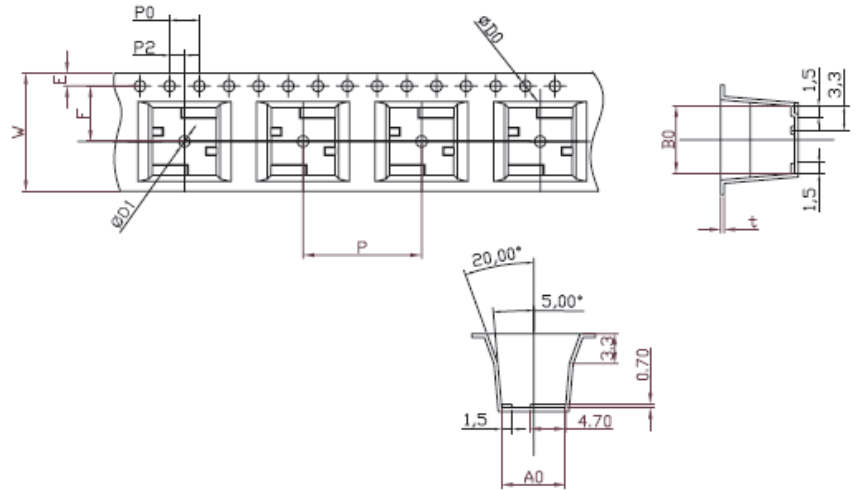

(Unit: mm)

■ Quantity

● Reel packing: 400 pcs per reel

Item	Nominal dimensions	Tolerance
D	330	±5
W	17.5	±0.5
t	5	±0.5
D1	75	±1.5

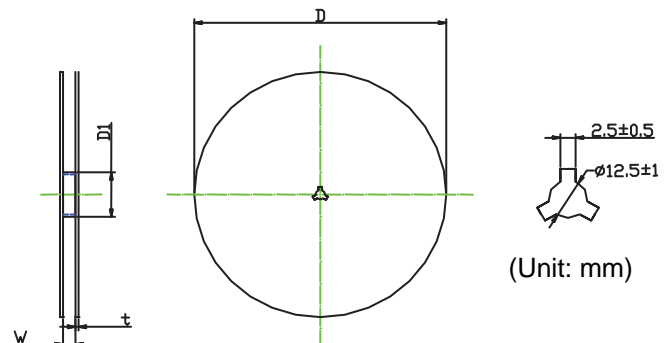

(Unit: mm)

■ Warehouse Storage Conditions of Products

● Storage Conditions :

1. Storage Temperature : $-10^{\circ}\text{C} \sim +40^{\circ}\text{C}$
2. Relative Humidity : $\leq 75\% \text{RH}$
3. Keep away from corrosive atmosphere and sunlight.

● Period of Storage : 1 year

■ Usage

Please keep products away from the conditions mentioned below to avoid their characteristic deterioration and failure.

1. Corrosive gas or deoxidizing gas (Cl_2 , H_2S , NH_3 , SO_x , NO_x etc.)
2. Place in a vacuum or put pressure
3. Salt water, oil, solvent and chemical liquid
4. Flammable gas
5. Place in splashed water, or high humidity and dewing place
6. Other places similar to any conditions mentioned above