



SPECIFICATION

Electrical Rating : 9A 125VAC 6A 250VAC (UL)
 4(1)A 250VAC (VDE)
 16A 250VAC/21A 125VAC(UL)
 16(6)A 250VAC(VDE) R91,R9D

Mechanical life: Over 30000 cycles
 Electrical life: Over 10000 cycles
 Contact resistance: <20mΩ
 Insulation resistance: >1000MΩ
 High voltage resistance: >1500VAC 1 min.
 Ambient temperature: Terminal side -20 to +85°C
 Actuating side- 20 to +55°C
 Atmospheric humidity: Max.85%
 Actuating force: 4 to 8N(depends on different switch function)
 Flammability: UL94V-2
 Storage temperature: -30 to +80°C Max
 Temperature rise at the terminal: Max 30°C (UL1054)
 Solder ability of terminal: Max 350°C 3s

MATERIALS

Housing: PA 66
 Rocker: PC & PA66
 Contact: Silver alloy
 Terminal: Brass silver plated
 Lamp: Neon lamp, Tungsten lamp, LED
 Movable arm: Beryllium copper



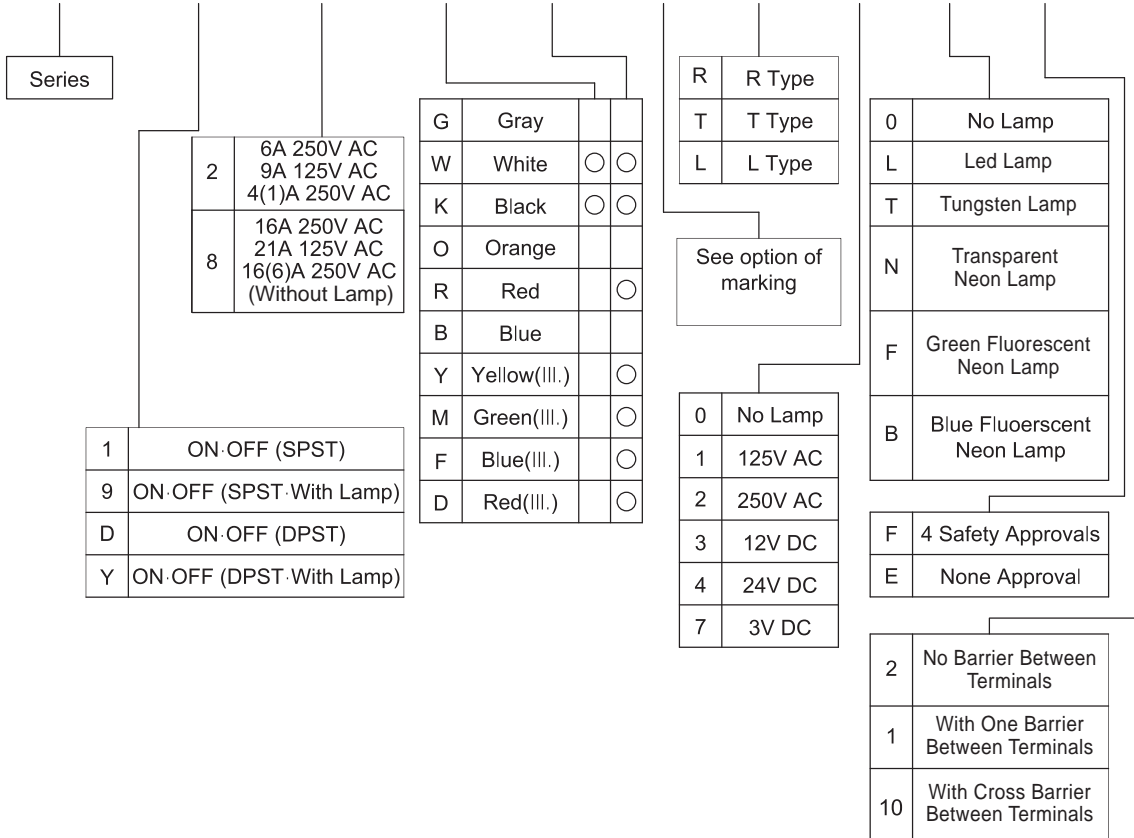

HOW TO ORDER

R9 **1** **2** **K** **K** **E** **T** **0** **0** **F** **1**
 Series Switch Function Rating Housing Color Actuator Color Marking Terminal Lamp Voltage Lamp Type Safety Approval



OPTIONS OF SWITCH FUNCTION / DIMENSION

Item Number	Poles & Throws	Rocker Position		
				
R91	SPST	ON	NONE	OFF
R99	SPST (WITH LAMP)	ON	NONE	OFF
R9D	DPST	ON	NONE	OFF
R9Y	DPST (WITH LAMP)	ON	NONE	OFF
R9I	Indicator			
R9B	The block sealed on the panel			

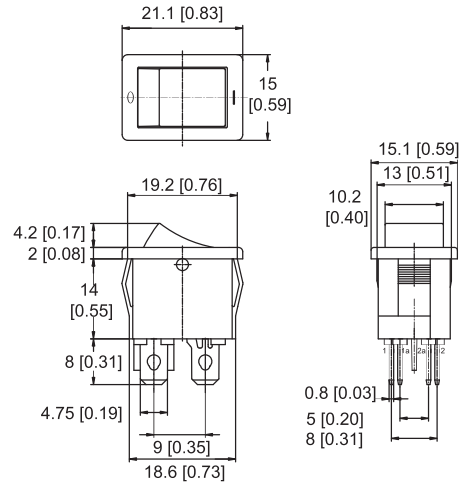

PANEL CUT OUT

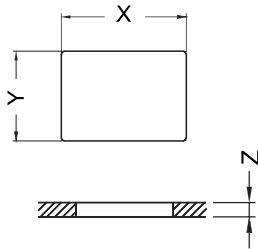

Z	Y	X
0.7~1.25	12.8~12.9	19.2~19.3
1.25~2.0	12.8~12.9	19.3~19.4
2.0~3.0	12.8~12.9	19.5~19.6

CIRCUITS FOR SWITCH WITH LAMP

For circuit of 250VAC, 125VAC with neon lamp
 For circuit of 24 VDC, 12 VDC, 6 VDC, 3 VDC with lamp
 For circuit of 48 with LED

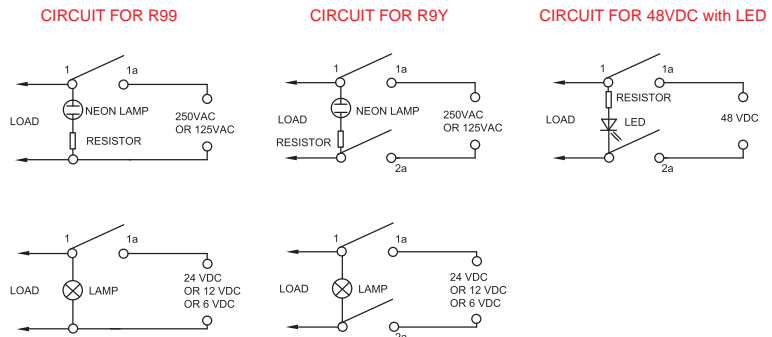

TERMINAL TYPE

T Type

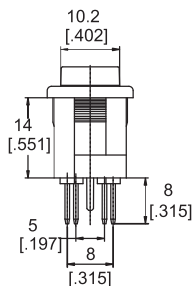

Quick Connect Tab

R Type

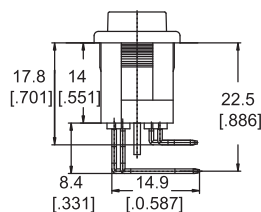

Right Angle PC Through Hole Terminal

L Type

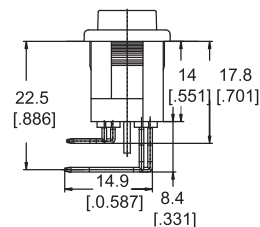

Left Angle PC Through Hole Terminal