

NTC Thermistor : TTF Series

Insulation Film Type for Temperature Sensing/Compensation

■ Features

1. RoHS compliant
2. Halogen-Free (HF) series are available
3. Radial leded insulation film coated
4. Operating temperature range: $-40^{\circ}\text{C} \sim +100^{\circ}\text{C}$
5. Agency recognition: UL / cUL

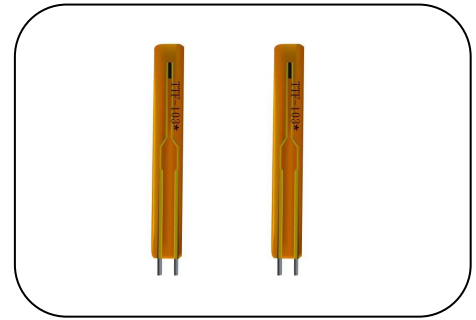

■ Recommended Applications

1. Home appliances
2. Computers
3. Battery packs

■ Part Number Code

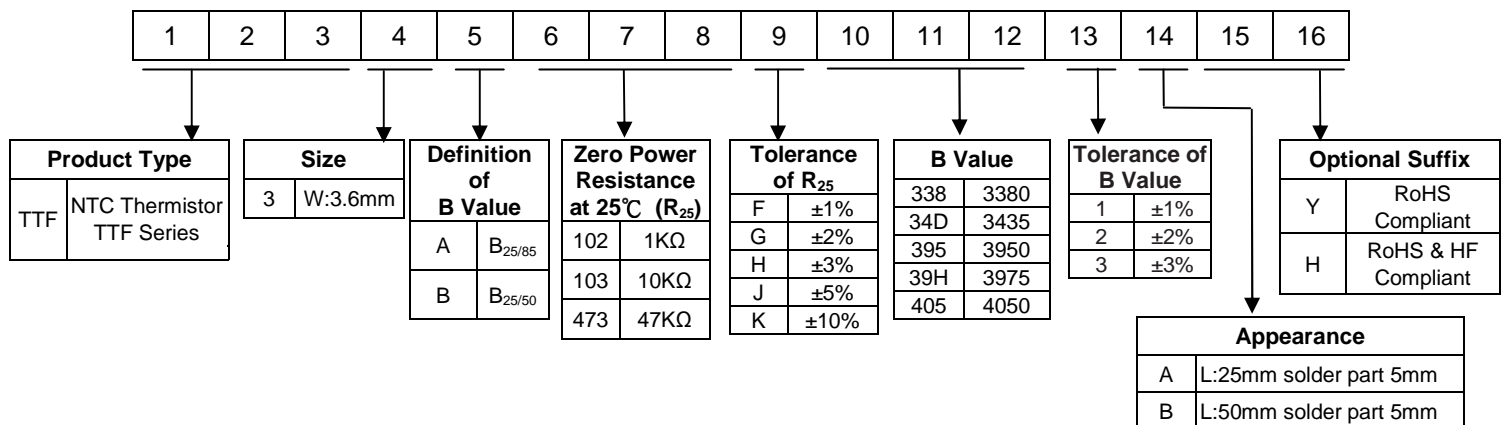

■ Structure and Dimensions

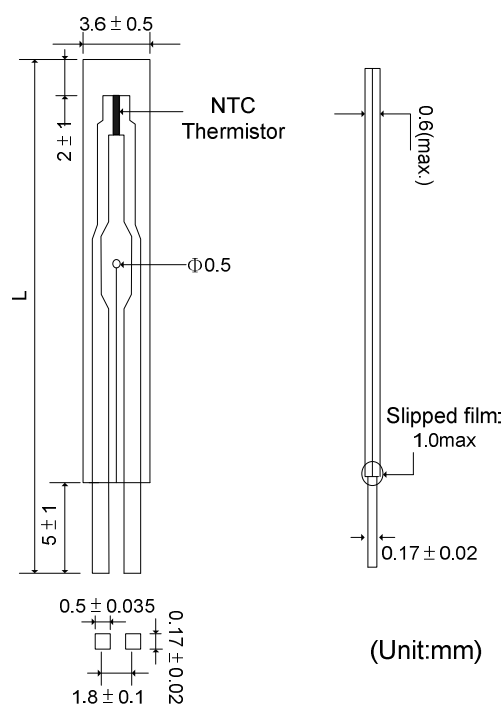

Insulation Film Type for Temperature Sensing/Compensation

Electrical Characteristics

| Part No. | Zero Power Resistance at 25°C | Tolerance of R ₂₅ | B Value | Tolerance of B value | Max. Power Dissipation at 25°C | Dissipation Factor | Thermal Time Constant | Operating Temperature Range | Safety Approvals | |
|---------------|-------------------------------|------------------------------|---------|----------------------|--------------------------------|--------------------|-----------------------|-------------------------------------|------------------|-----|
| | R ₂₅ (KΩ) | (±%) | (K) | (±%) | P _{max} (mW) | δ(mW/°C) | τ (Sec.) | T _L ~T _U (°C) | UL | cUL |
| TTF3A502□34D* | 5 | 1, 2, 3, 5 | 25/85 | 3435 | 3.5 | Approx. 0.7 | Approx. 5 | -40 ~ +100 | √ | √ |
| TTF3A103□34D* | 10 | | | 3435 | | | | | √ | √ |
| TTF3A203□34D* | 20 | | | 3435 | | | | | √ | √ |
| TTF3A223□34D* | 22 | | | 3435 | | | | | √ | √ |
| TTF3A303□39H* | 30 | | | 3975 | | | | | √ | √ |
| TTF3A104□34D* | 100 | | | 3435 | | | | | √ | √ |

Note 1: □ = Tolerance of R₂₅

* = Tolerance of B value

Note 2: Special specifications are available upon request.

Max. Power Dissipation Derating Curve

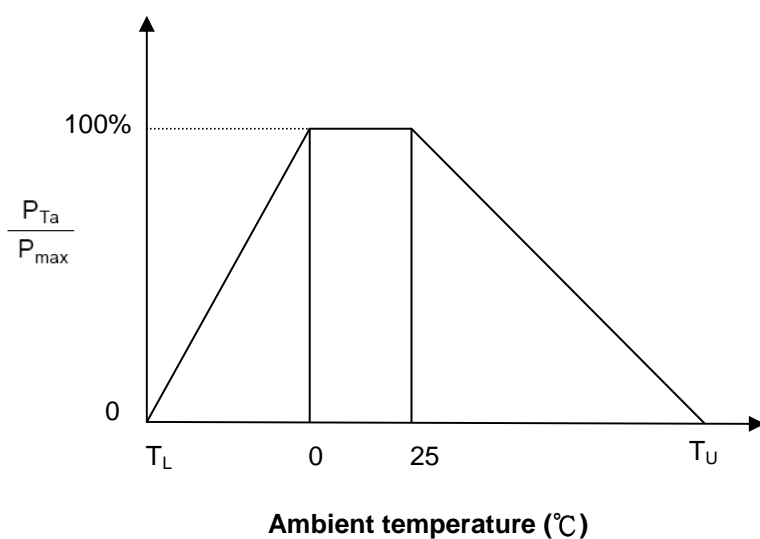

T_U: Maximum operating temperature (°C)

T_L: Minimum operating temperature (°C)

For example:

Ambient temperature(T_a) = 55°C

Maximum operating temperature(T_U) = 100°C

$P_{Ta} = (T_U - T_a) / (T_U - 25) \times P_{max} = 60\% P_{max}$

■ R-T Characteristic Curves

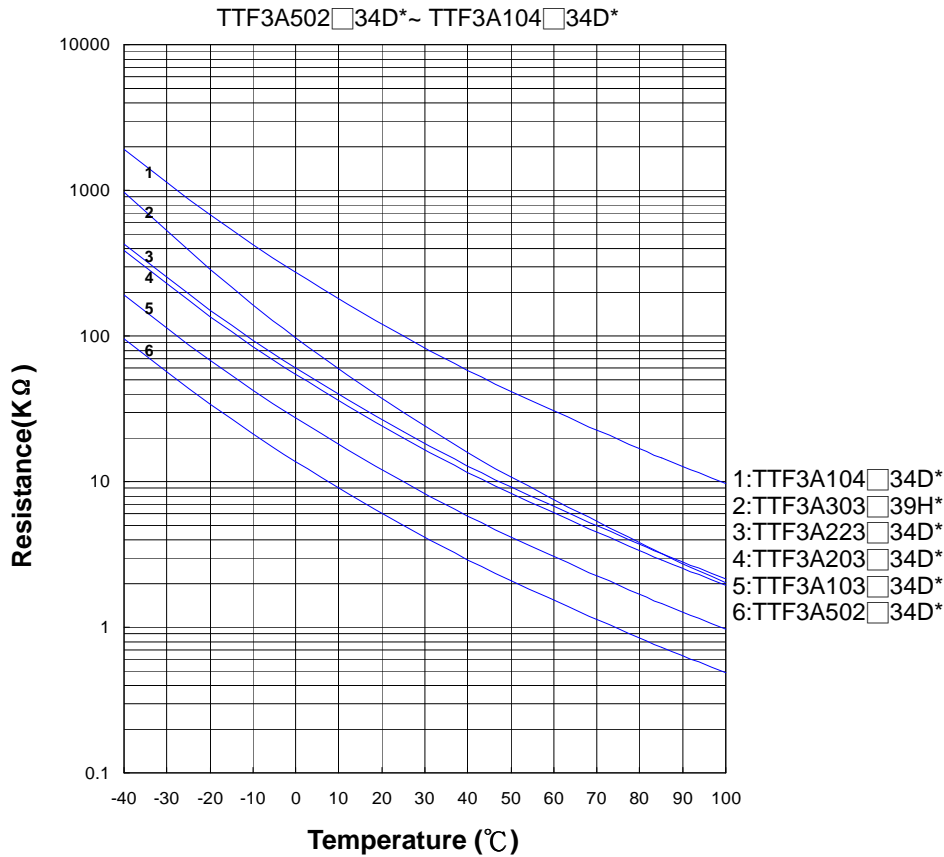

■ Soldering Recommendation

● Wave Soldering Profile

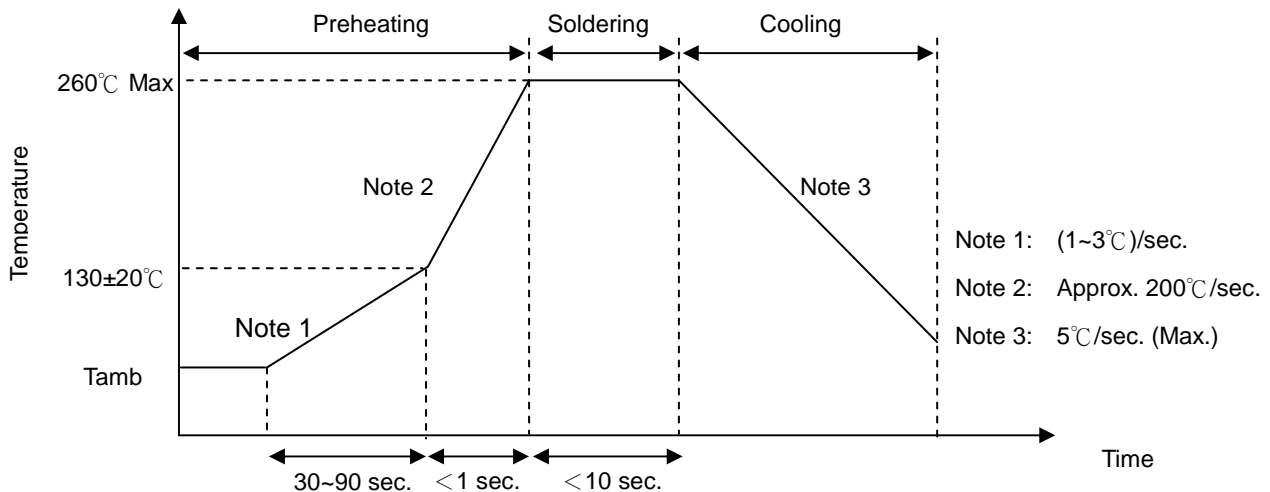

● Recommended Reworking Conditions with Soldering Iron

| Item | Conditions |
|-----------------------------------|--------------------------|
| Temperature of Soldering Iron-tip | 360°C (max.) |
| Soldering Time | 3 sec. (max.) |
| Distance from Coating | Do not touch film bottom |

Insulation Film Type for Temperature Sensing/Compensation

■ Reliability

| Item | Standard | Test conditions / Methods | Specifications | | | | | | | | | | | | | | | |
|---|------------------|--|--|------------------|------------------|-------|-------------------|--------|---|------------------|-------|---|---------|--------|---|------------------|-------|--|
| Tensile Strength of Terminals | IEC 60068-2-21 | <p>Gradually apply the specified force and keep the unit fixed for 10±1 sec.</p> <table border="0"> <tr> <td style="text-align: center;">Terminal cross-sectional area (mm²)</td> <td style="text-align: center;">Force (Kg)</td> </tr> <tr> <td style="text-align: center;">0.05<S≤0.1</td> <td style="text-align: center;">0.25</td> </tr> </table> | Terminal cross-sectional area (mm ²) | Force (Kg) | 0.05<S≤0.1 | 0.25 | No visible damage | | | | | | | | | | | |
| Terminal cross-sectional area (mm ²) | Force (Kg) | | | | | | | | | | | | | | | | | |
| 0.05<S≤0.1 | 0.25 | | | | | | | | | | | | | | | | | |
| Bending Strength of Terminals | IEC 60068-2-21 | <p>Hold specimen and apply the force specified below to each lead. Bend the specimen to 90°, and then return to the original position. Repeat the procedure in the opposite direction.</p> <table border="0"> <tr> <td style="text-align: center;">Terminal cross-sectional area (mm²)</td> <td style="text-align: center;">Force (Kg)</td> </tr> <tr> <td style="text-align: center;">0.05<S≤0.1</td> <td style="text-align: center;">0.125</td> </tr> </table> | Terminal cross-sectional area (mm ²) | Force (Kg) | 0.05<S≤0.1 | 0.125 | No visible damage | | | | | | | | | | | |
| Terminal cross-sectional area (mm ²) | Force (Kg) | | | | | | | | | | | | | | | | | |
| 0.05<S≤0.1 | 0.125 | | | | | | | | | | | | | | | | | |
| Solderability | IEC 60068-2-20 | 245 ± 3°C, 3 ± 0.3 sec. | At least 95% of terminal electrode is covered by new solder | | | | | | | | | | | | | | | |
| Resistance to Soldering Heat | IEC 60068-2-20 | 260 ± 3°C, 10 ± 1 sec. | No visible damage ΔR ₂₅ /R ₂₅ ≤ 3 % | | | | | | | | | | | | | | | |
| High Temperature Storage | IEC 60068-2-2 | 100 ± 5°C, 1000 ± 24 hrs | No visible damage ΔR ₂₅ /R ₂₅ ≤ 5 % | | | | | | | | | | | | | | | |
| Damp Heat, Steady State | IEC 60068-2-78 | 40 ± 2°C, 90~95% RH, 1000 ± 24 hrs | No visible damage ΔR ₂₅ /R ₂₅ ≤ 3 % | | | | | | | | | | | | | | | |
| Rapid Change of Temperature | IEC 60068-2-14 | <p>The conditions shown below shall be repeated 5 cycles.</p> <table border="1"> <thead> <tr> <th>Step</th> <th>Temperature (°C)</th> <th>Period (minutes)</th> </tr> </thead> <tbody> <tr> <td>1</td> <td>-40 ± 5</td> <td>30 ± 3</td> </tr> <tr> <td>2</td> <td>Room temperature</td> <td>5 ± 3</td> </tr> <tr> <td>3</td> <td>100 ± 5</td> <td>30 ± 3</td> </tr> <tr> <td>4</td> <td>Room temperature</td> <td>5 ± 3</td> </tr> </tbody> </table> | Step | Temperature (°C) | Period (minutes) | 1 | -40 ± 5 | 30 ± 3 | 2 | Room temperature | 5 ± 3 | 3 | 100 ± 5 | 30 ± 3 | 4 | Room temperature | 5 ± 3 | No visible damage ΔR ₂₅ /R ₂₅ ≤ 3 % |
| Step | Temperature (°C) | Period (minutes) | | | | | | | | | | | | | | | | |
| 1 | -40 ± 5 | 30 ± 3 | | | | | | | | | | | | | | | | |
| 2 | Room temperature | 5 ± 3 | | | | | | | | | | | | | | | | |
| 3 | 100 ± 5 | 30 ± 3 | | | | | | | | | | | | | | | | |
| 4 | Room temperature | 5 ± 3 | | | | | | | | | | | | | | | | |
| Max. Power Dissipation | IEC 60539-1 | 25 ± 5°C, Pmax. , 1000 ± 24 hrs | No visible damage ΔR ₂₅ /R ₂₅ ≤ 5 % | | | | | | | | | | | | | | | |

■ Packaging

- **Bulk Packing:** 500 pcs/ bag

■ Warehouse Storage Conditions of Products

- Storage Conditions:
 1. Storage Temperature: -10°C ~+40°C
 2. Relative Humidity: ≤75%RH
 3. Keep away from corrosive atmosphere and sunlight.
- Period of Storage: 1 year