

GLASS PASSIVATED SINGLE-PHASE BRIDGE RECTIFIER

GBPC1005 THRU GBPC110

FEATURES

- Plastic package has underwriters laboratory
- Flammability classification 94V-0
- Glass passivated ship junction
- High case dielectric with standing voltage of 1500V_{RMS}
- Typical I_r less than 0.1 μA
- High surge current capability
- Ideal for printed circuit boards
- High temperature soldering guaranteed 260°C/10 seconds, 0.375" (9.5mm) lead length at 5 lbs (2.3kg) tension

MECHANICAL DATA

- Case: Epoxy, Molded Plastic body over passivated junctions
- Terminal: Plated leads solderable per MIL-STD-750 method 2026
- Mounting position: Any (Note 1)
- Weight: 0.1 ounce, 2.8 gram

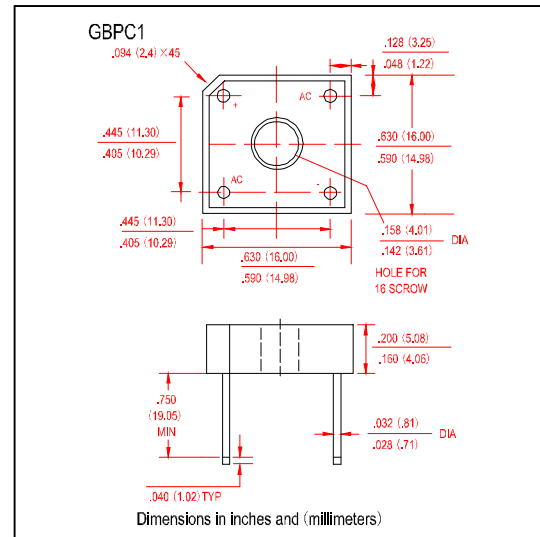

MAXIMUM RATINGS AND ELECTRICAL CHARACTERISTICS

- Ratings at 25°C ambient temperature unless otherwise specified

	SYMBOLS	GBPC 1005	GBPC 101	GBPC 102	GBPC 104	GBPC 106	GBPC 108	GBPC 110	UNIT
Maximum Repetitive Peak Reverse Voltage	V _{RRM}	50	100	200	400	600	800	1000	Volts
Maximum RMS Voltage	V _{RMS}	35	70	140	280	420	560	700	Volts
Maximum DC Blocking Voltage	V _{DC}	50	100	200	400	600	800	1000	Volts
Maximum Average Forward output current at	T _C =60°C (Note 2)	3.0							Amps
	T _A =25°C (Note 3)	2.0							
Peak Forward Surge Current single half sine-wave superimposed on rated load (JEDEC method) T _C =60°C	I _{FSM}	60							Amps
Maximum Instantaneous Forward Voltage Drop Per element at 1.5A	V _F	1.0							Volts
Rating for Fusing (t < 8.3ms)	I ² t	127							A ² s
Maximum Average Reverse Current at rated DC Blocking Voltage	T _A = 25°C	5.0							μA
	T _A = 125°C	500							
Typical Thermal Resistance per leg (NOTE 1)	R _{θJL}	8.0							°C/W
	R _{θJA}	12							
Operating and Storage Temperature Range	T _J , T _{STG}	(-55 to +150)							°C

- Notes:**
1. Bolt down on heatsink with silicon thermal compound between bridge and mounting surface for maximum heat transfer with #6 screw.
 2. Unit mounted 1.0"×4.0"×0.11" thick (10.5×10.5×0.3cm) Al. Plate
 3. Unit mounted on P.C.B. at 0.375" (9.5mm) lead with 0.5"×0.5" (12×12mm) copper pads

GLASS PASSIVATED SINGLE-PHASE BRIDGE RECTIFIER

GBPC1005 THRU GBPC110

RATINGS AND CHARACTERISTICS CURVES GBPC1005 THRU GBPC110

